

Miniveyor™

The Powerful Portable Conveyor System

Operators Manual



EC Declaration of Conformity & TUV

CONTENTS

Declaration of Conformity	3
Important Safety Information	4
Miniveyor Range and Identification of Components	5
Miniveyor Accessories and recommended use	6-7
The Miniveyor System	
Deciding your requirements and choosing the right Miniveyor for the job	8
Conveying different materials in varying site conditions	8
Setting up a typical installation	8
Miniveyor Requirements	9
Setting up	10
Connecting the Electrical System	11
Loading the Miniveyor System safely	12
Stopping	12
Basic Maintenance	13
Operators Maintenance	
Fault finding chart	14
Parts List	
M40P/C1 and M40C-2 part list	15
M52C-2 part list	16
Original Control Box parts list	17
Inline Control Box parts list	18
Warranty information	19



Make sure you know how to stop it before you start it!

These instructions are for your protection and convenience. Please read them carefully, there is a serious risk of personal injury if you do not follow all instructions.

This equipment is designed to be used by able bodied, competent adults who have read and understood these instructions. Anyone with either a temporary or permanent disability should seek expert advice before using it. Never use this equipment if you are ill, feeling tired, or under the influence of alcohol or drugs. Do not try to manually lift it with out checking the weight and taking proper precautions. Wear practical, protective clothing, avoid loose garments and jewellery that could catch in moving parts, tie back long hair. Keep hair, loose clothing, fingers, and all parts of body away from the belt and other moving parts.

Check the condition of the equipment before use. If the equipment fails, or if its power supply cable plug, or control box gets damaged, get it repaired. Keep cables out of harm's way, and clear of damage by others. Do not pull or carry by the cable, do not use the cable as a handle or handle the plug or cable with wet hands.

Do not unplug by pulling the cable; to unplug, grasp the plug not the cable. Extension leads should be fully unwound and loosely coiled, away from the equipment.

Never run electric cables through water, near heated surfaces, over sharp edges or where they could trip someone or be run over by vehicles
Keep the equipment dry; using electrical equipment in very damp or wet conditions can be dangerous.

To reduce the risk of electric shock, always use a suitable RCD (Residual Current-Operated Device).

If you are in any doubt consult a qualified electrician.

Keep children, animals and bystanders away from the work area. When using Miniveyors in elevated positions where people can walk underneath, additional safety precautions may be necessary to stop material or debris falling on personnel.

Do not allow the equipment to be used as a toy. Close attention is necessary when used by or near children. An Emergency Stop Box is available to enable an Emergency Stop or Remote Stop when required. Health and Safety Officers may require its use when a clear view of the complete system is not possible.

Always switch OFF and disconnect the equipment before making adjustments to it. If the Miniveyor is not working as it should, because it has been damaged, contact your hire company.

Miniveyor • Range & Identification of Components

3M40P-1:
10' long and 15" wide with
a plain belt and 1 motor

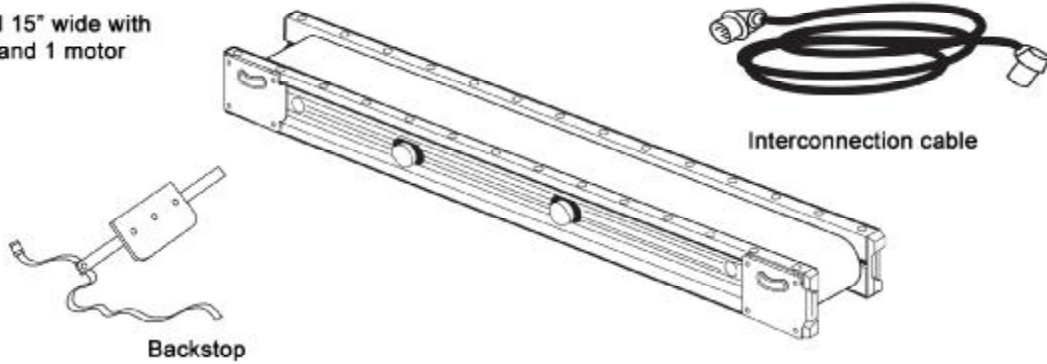

3M40C-1:
10' long and 15" wide with
a cleated belt and 1 motor

3M40C-2:
10' long and 15" wide with a
cleated belt and 2 motors

3M40C-1HP:
10' long and 15" wide with a
3/4 inch cleated belt and 1 high
power motor

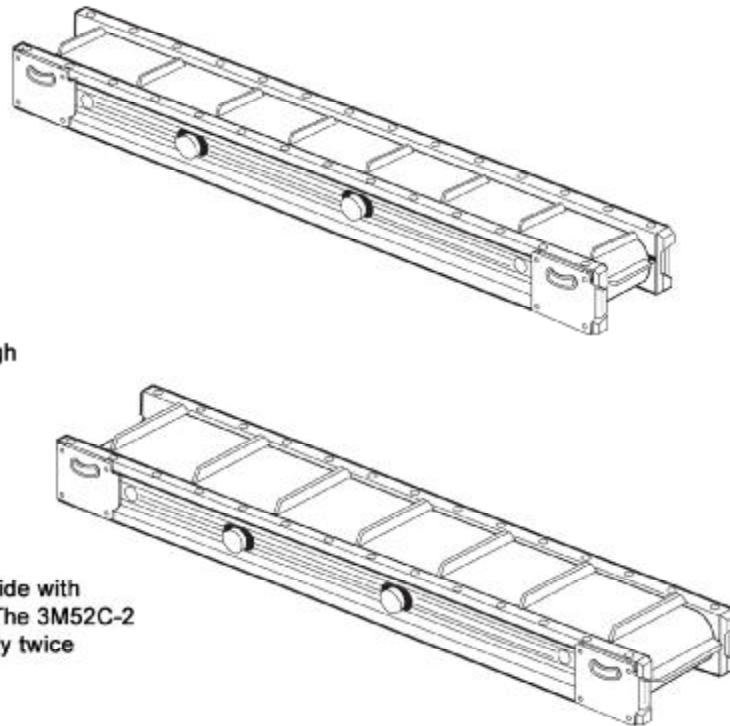

3M52C-2: 10' long and 20" wide with
a cleated belt and 2 motors. The 3M52C-2
which can move approximately twice
the volume of the 3M40.

Control boxes There are two versions: "Original" (No longer available) manufactured with standard electrical components for easy maintenance/servicing or "In Line" with fitted cables and heavy duty printed circuit board.

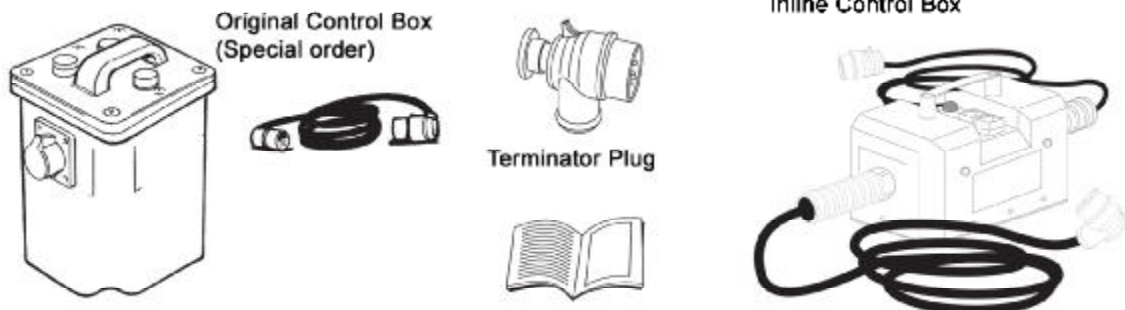

Miniveyor • Accessories

Accessories - we have developed a range of accessories to make your job easier.

LOADING



Hand Loading Hopper

For two people loading by hand and can be used with 6' x 6' side extensions.

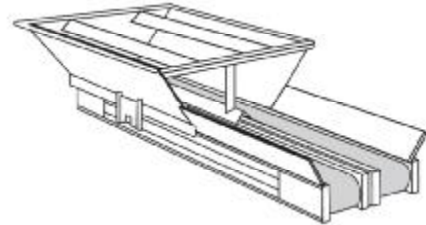

Double Miniveyor Hopper

The double hopper runs two Miniveyours side by side; doubling output.

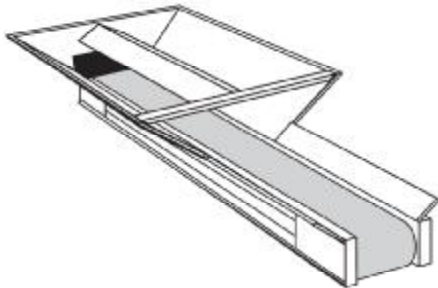

Minidigger Hopper

For Loading by Minidigger and includes 6' X 6' side extensions.

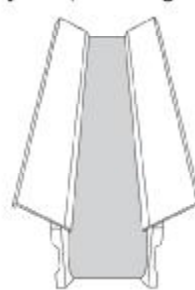

Side Extensions

If you load with a Minidigger, side extensions are essential.
6' MVA-070400
10' MVA-070480

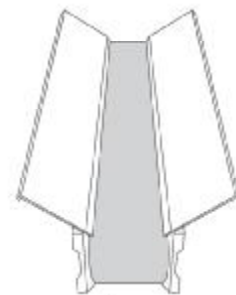

15° deep side extensions for Skid Steer loading MVA-070120

SETTING UP

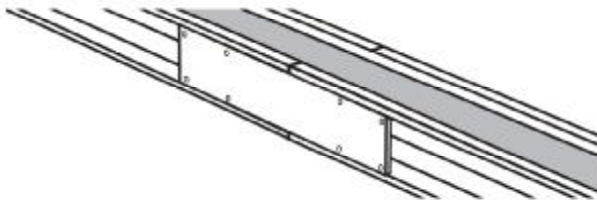

20 Foot Kit

A kit to convert two 10 foot Miniveyours into one 20 foot length. MVA- 07300K

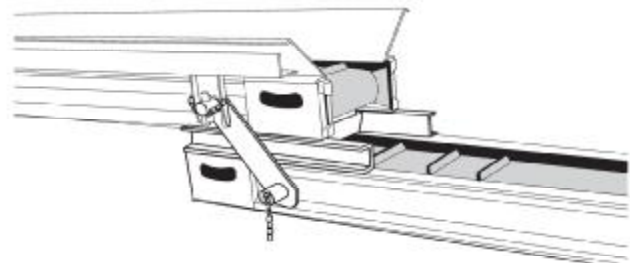

Clamp Kit

For linking two 10 foot Miniveyours together in about 60 seconds. MVA-073010

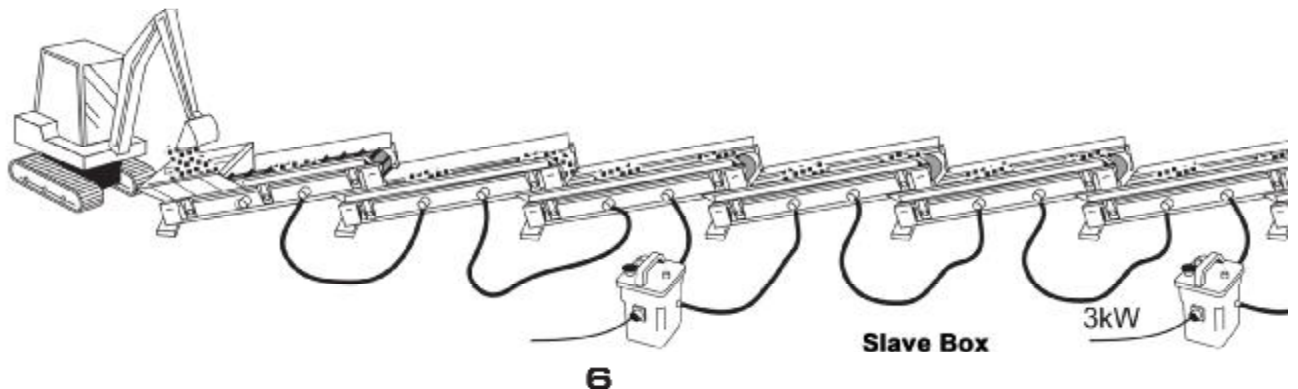

Miniveyor • Accessories

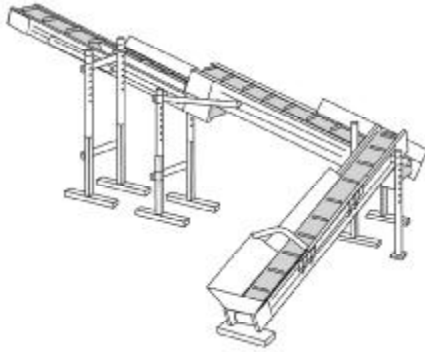

Support Feet Kit

Enables three Miniveyors to be supported from ground level to the next floor level, using the scaffold tube location hole. MVA - 072010

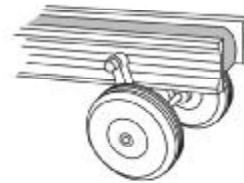

Wheels

A set of wheels enables one person to move units by themselves, particularly useful when collecting them from site.



Slave Box

The Slave control box enables additional Miniveyors to be connected in-line, whilst stop/start control is from the Control Box. An additional power supply is required.



Emergency Stop Box

This enables emergency stopping of all connected Miniveyor units and can be connected at any point in the system. 110VMVA0020600 230VMVA-021000



Electrical Safety Test Cable

For safety testing of all the 110 Volt Miniveyors and Control Box. The cable enables connection to electrical safety testing machine with a 3 pin, 110 volt socket. MVA-02740T

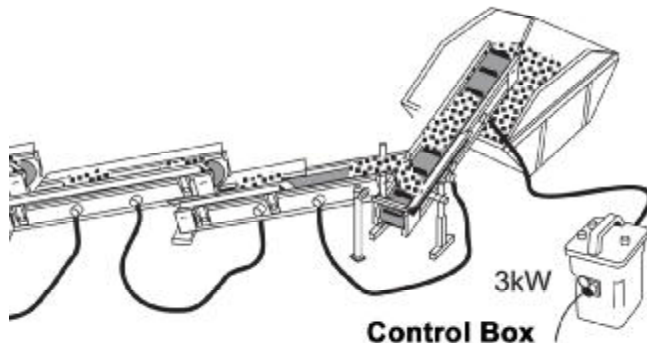

SERVICING



Belt Adjusting Tool

For adjusting the Miniveyor belt tension, with the cam adjusters. MVT-000100



Belt Jointing Machine

A special tool for fitting the stainless steel fasteners to the end of the belt, we also supply a large T square for accurately cutting the belt at 90 degrees. Important, the stainless steel fasteners MVB-011130 are supplied in boxes of 12, suitable for 6 belts.

USING THE SLAVE BOX

This layout shows how the slave boxes work in conjunction with the control box, in a line of Miniveyors. Miniveyors can be used to move material over long distances, and we have been asked for installations of 300 Feet and more. With long Miniveyor installations that can disappear around corners, it may be more convenient and safer if all the Miniveyors are started from one position and stopped from any position. A Control Box can start and stop all connected Miniveyors, and subsequent Slave Boxes can stop all connected Miniveyors.

Miniveyor • Setting Up and Operation

1) Difficult Access? Material to Move?

You can easily fit Miniveyors into most situations; they are only 10 feet long, 15 inches or 20 inches wide and 7 1/2 inches high. They can be laid along the ground, up staircases, over (small) rivers, up out of cellars; they are versatile. Miniveyors replace buckets, wheelbarrows and dumpers, and will almost always save you money, time and manpower.

Inclines: Going up a slope? Miniveyors really come into their own with inclines; the Miniveyor 3M40P-1 (fitted with plain / smooth belts) can operate up to about 30 degree inclination, depending on the type of load and conditions. Miniveyors 3M40C (fitted with cleated belts), will operate up to approximately 40 degrees. When Miniveyors are steeply inclined you will see that the volume of material conveyed reduces as the angle of inclination increases.

Conveying of Blocks, Bricks etc: When moving a load that has no loose material, Miniveyors can be butted together instead of overlapping.

If the job is critical, consult your dealer Miniveyor Systems Inc. at the planning stage. Every load conveys differently and where throughput is critical, conduct a practical test to establish the best solution.

Wet loads: No special precautions are necessary when handling wet loads as the Miniveyor electrical system is water resistant to IP44. We just recommend that you wash them afterwards.

Concrete: We do NOT recommend conveying wet concrete; because when the concrete dries and becomes solid, operation of the conveyor may be impaired. If Miniveyors are used for concrete remember to clean them immediately after use with a high-pressure washer. Tell your hire company / dealer that the units have been used for concrete so that any additional required action can be taken before it is too late and expensive.

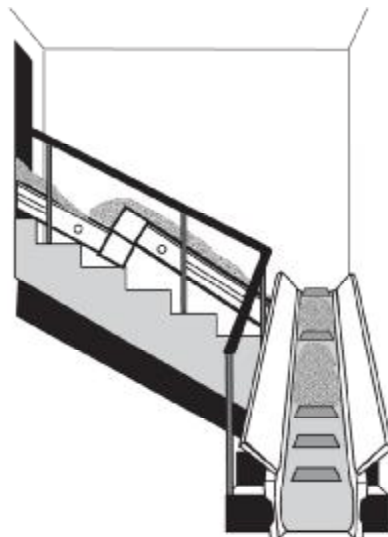
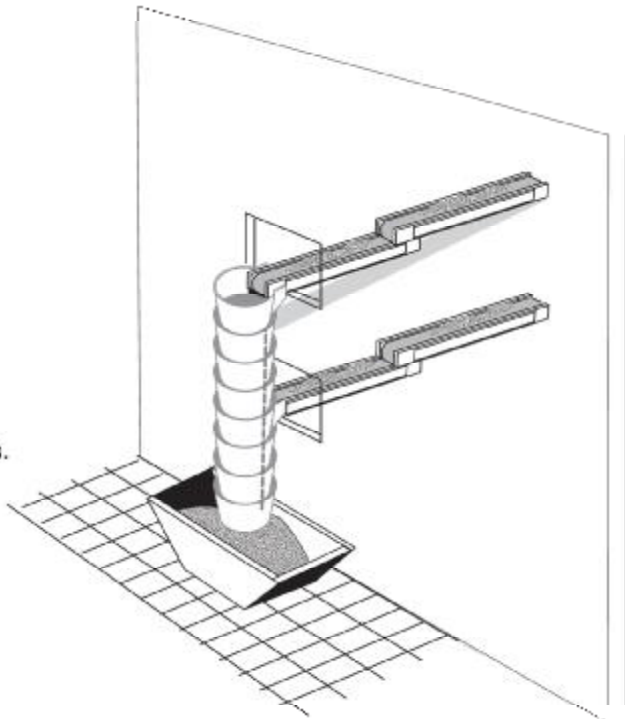

Use in a cellar or upstairs

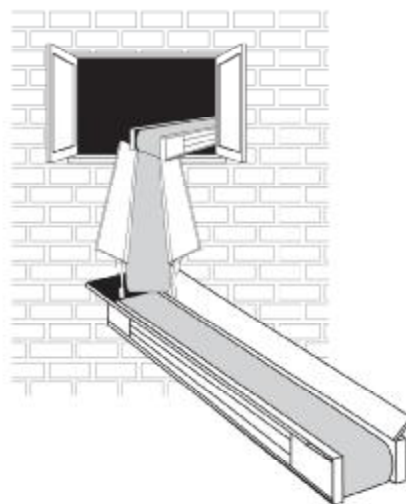

Output through a window

Miniveyor • Setting Up and Operation

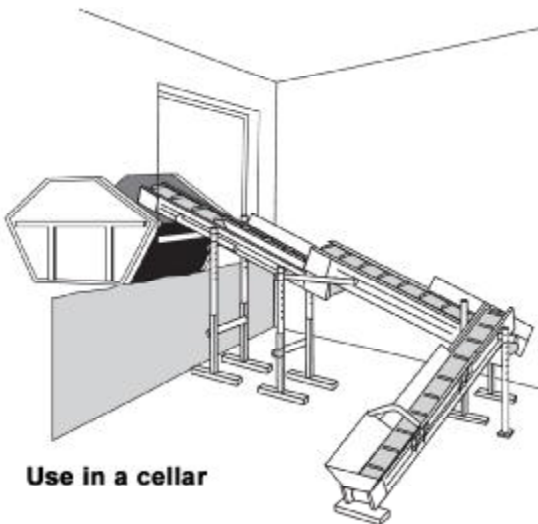

Use in a cellar

2) Miniveyor solution:

When you have a skilled team it often makes sense to use the right tools for the job. There is no wasted time picking up a bucket, or wheelbarrow, or driving a dumper. You just need enough men to shovel; loading sand, stones, earth, screed, any loose material - they are the tool for you. Miniveyors can move up to 25 tons per hour.

Miniveyors can operate anywhere from -10 degrees Celsius (14 degrees Fahrenheit) to +30 degrees Celsius (86 degrees Fahrenheit); in the rain, mud and snow!

The basic elements of a Miniveyor System are:

- (1) The Miniveyors
- (2) Interconnection Cables: -One per Miniveyor
- (3) 20 amp Control box.
- (4) Terminator Plug: - One per control box.
- (5) Accessories, we have developed a range of accessories to make your job easier: loading hoppers, side extensions etc.

3) What do I need - How many?

Deciding how many Miniveyors is straight forward, however because you will find that Miniveyors are very effective, you will want more units as you appreciate their advantages. Just measure the overall distance you want your material conveyed, then allow one unit for every 9 feet (this allows for a 1 foot overlap).

Each Control Box and each Slave Box requires a 20 amp power supply. A Miniveyor 3M40P-1 is fitted with one motor; and the Miniveyor 3M40C-2 and 3M52C-2 are fitted with two motors. Each 20 amp Control Box / Slave Box will power, depending on load approximately

	3M40P/C -1	3M40C -1HP	3M52C -1HP	3M52C -2	3M52C -2
110 Volts	4 units	4 units	3 units	3 units	2 units
230 Volts	8 units	5 units	5 units	4 units	3 units
3 Phase	15 units	- units	- units	7 units	7 units

Important - The extension cable should be less than 150 feet and NOT less than 10/3 cable or you will experience voltage drop.

Loading hoppers and Side Extensions can be used to reduce spillage anywhere along the system. If you are loading with a Minidigger you will need our Minidigger hopper on a Miniveyor 3M40C-1HP.

Miniveyors are generally 110 volt, 230 volt or 3 phase; we do also offer both hydraulic and pneumatic as well.

Miniveyor • Typical Applications

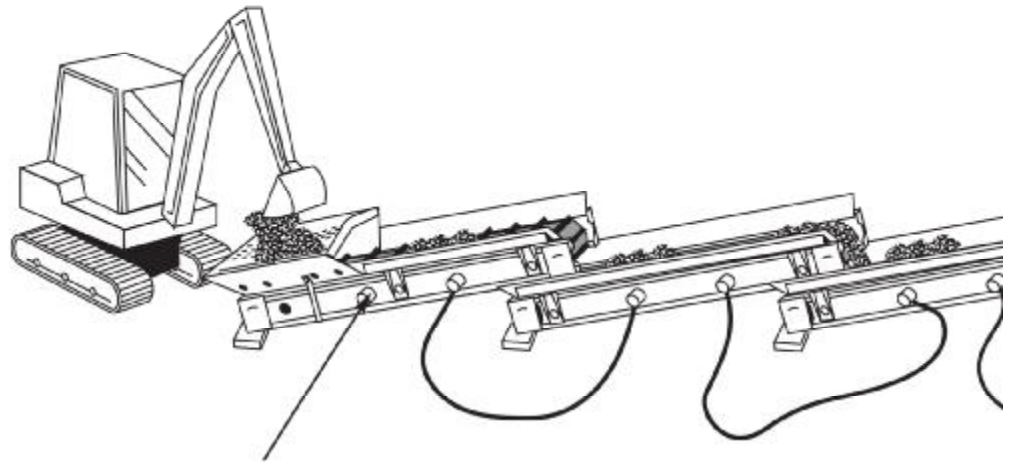

Terminator Plug

4) Setting Up Miniveyors

Before you start setting up just check that you have everything that you need: Miniveyors, Control Boxes, Terminator Plugs, Loading Hoppers, Side Extensions, extension leads, and scaffolding support if required. Remember when hand carrying; that the Miniveyor 3M40 weighs about 160 lbs; the wider Miniveyors 3M52 weigh about 196 lbs.

Important:

Miniveyors must always be used the right way up, with the felt "Side Seals" on top.

Use with scaffolding: Miniveyors can be easily incorporated into scaffolding by using the scaffold tube hole at each end.

When laying out Miniveyors always consider the difficult bit first. If you want to remove material from a cellar decide if you will use the staircase or window first; then, how you will support the Miniveyor - scaffolding is a very flexible solution. Remember to allow sufficient height when you exit the staircase or window for the next miniveyor. Adding Miniveyors across the level in the cellar and along ground level into the dumpster is generally straight forward, just remember to position the next Miniveyor so that the material falls straight into it.

Pre-Start inspection

Before starting your Miniveyors, walk along the length of the installation and check that they are safely laid out and that all cables and plugs are in good condition and fully inserted. Ensure that personnel on the site know that the Miniveyor could be in operation soon and that any additional guarding required is in place. Some spillage of material may occur at transfer points, but this can be reduced by using hoppers and side extensions.

Miniveyor • Starting and Stopping

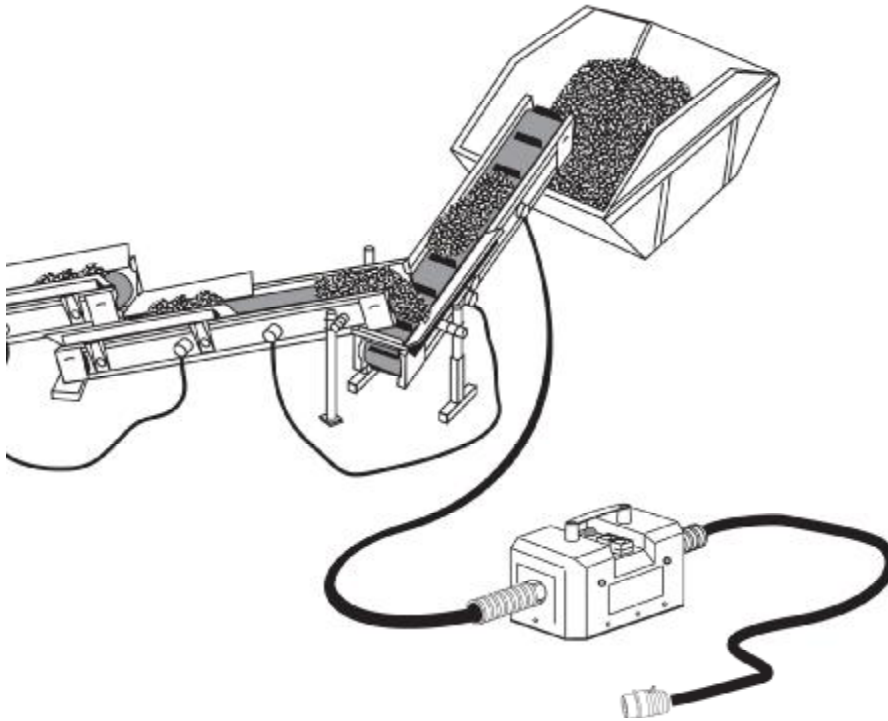

5) Connecting up the Electrical Supply

If you are not sure of normal building site requirements for electrical power supplies, please consult a competent Electrician or site Safety Officer before connecting up the system. It is strongly recommended that the electric power supply is protected by an earth leakage cut out system, know as an R.C.D. unit (Residual Current Device).

Miniveyors must only be connected to a Miniveyor Control Box using the correct cables. Miniveyors with yellow plugs and sockets are for 110 volt AC supply only; blue plugs and sockets are for 230 volts only; and red plugs and sockets are 3 phase only.

Connecting up

Each Miniveyor has two plug connections/sockets: one for each direction of travel. Plug the first Interconnecting Cable from the control Box into the right sockets of the first Miniveyor and the belt will move to the right. Swapping the plugs over changes the belt direction. Be gentle but firm in the fitting and removal of plugs.

Then plug in the next Interconnecting Cable; from the second socket into the next Miniveyor; and so on, until all the Miniveyors are connected up. Don't exceed the maximum quantity of Miniveyors (motors) per Control Box and Don't forget the Terminator Plug in the last empty socket. It won't work with out it.

Starting Procedure

Switch on the power supply and check that both the red and green lights are illuminated on the Control Box. Press the illuminated green button; the Miniveyors will then start, slowly at first, but increasing within a few seconds to operating speed. Please run them for a couple of minutes before loading materials onto the belt. When very cold, start one Miniveyor at a time.

Miniveyor • Operating Hints

6) The System is working;

Once the system is set up and working, you are ready to move material. Loading can be by hand and provided there is enough room, at least two people should be able to use full capacity of the Miniveyor. Frequently Minidiggers are now used to load Miniveyors, however you should ensure that the Miniveyors are right next to the material. If you take longer than 6 seconds between bucket loads you are losing volume.

Loading is the most important item; you need a hopper and means of loading it fast.

Miniveyors can move large volumes:
3M40 up to 20 -25 tons an hour
3M52 up to 40-50 tons an hour

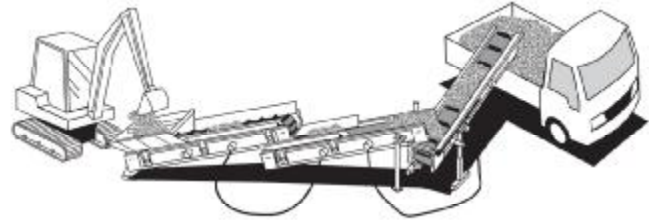

When you are loading into trucks over pavements care must be taken to avoid spillage and this is where we recommend Side Extensions. These keep bulky material on the belt.

7) Maintenance

The Miniveyor system requires a little on-going maintenance. The best maintenance is cleaning down the Miniveyors after each use with a hose or high pressure washer until the water runs clean (Avoid direct pressure jetting of the plugs and sockets). This means removing any material or dirt that accumulates under the belt.

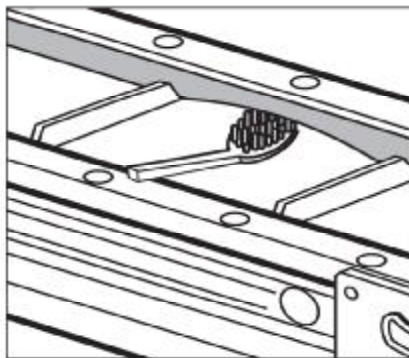

Occasionally you should grease the Side Seals, the important area is just under the lower edge that rests on the belt, this reduces frictional losses considerably. Greasing can be required frequently / weekly if constantly used.

When greasing them always check the Side seals for tearing or damage and replace if necessary.

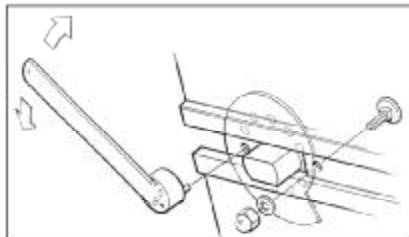

Again "occasionally" the belt requires tensioning and tracking. The belt should run with adequate tension (without slippage) and this is adjusted by the cams as shown.

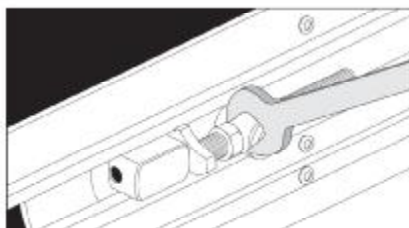

For HP models adjust using the belt tension screws.

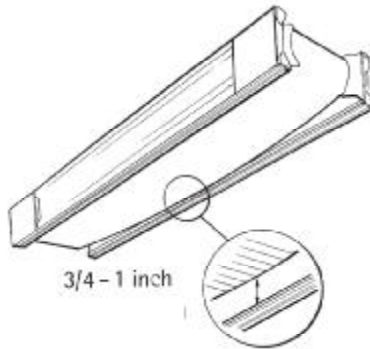

The required belt tension can be measured in the middle under the Miniveyor as shown:

The measurement should be approximately 3/4 to 1 inch, but you will see this fluctuate as the belt rotates.

Tracking the belt means that it should run **centrally** in the conveyor, **NOT** touching either side, this keeps wear and frictional losses down.

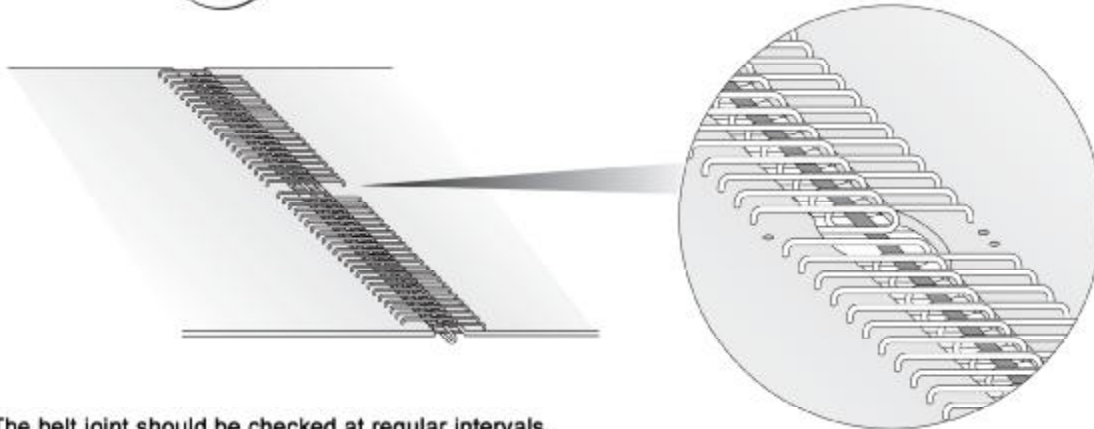

The belt joint should be checked at regular intervals.
If there are three consecutive hooks missing the belt must be rejoined.

8) Several Miniveyor Facts

The Miniveyor system is one of safety. We have a 24 volt safety circuit that runs from the control box, through every Miniveyor to the Terminator Plug and back to the control box. If the safety circuit is not complete with every plug and the Terminator Plug fully inserted, the main electrical voltage will NOT be switched on.

The Miniveyor system cools itself by transferring heat generated in the drum to the belt and then to the load. As every motor is fitted with "over temperature sensors" it is very unlikely that a drum motor will burn out. Instead, all Miniveyors connected to the control box will stop as the thermal sensor breaks the safety circuit. Both lights on the control box will stop as the thermal sensor breaks the safety circuit. Both lights on the control box only work if the safety circuit is complete, so if they are not illuminated there is an electrical problem rather than mechanical. If the thermal sensors trip the safety circuit then you will have to wait for several minutes until it reconnects and the lamps are illuminated again.

If you have a mechanical problem this may be due to overloading or the undersides of the belts sinking into soft ground and catching cleats; mechanical problems are normally visible.

Remember we are ready to help you, just ask, what ever your question. Either your dealer, or you can contact us direct; we will be pleased to help.

Miniveyor • Fault Finding

