

DEWALT®

DW718

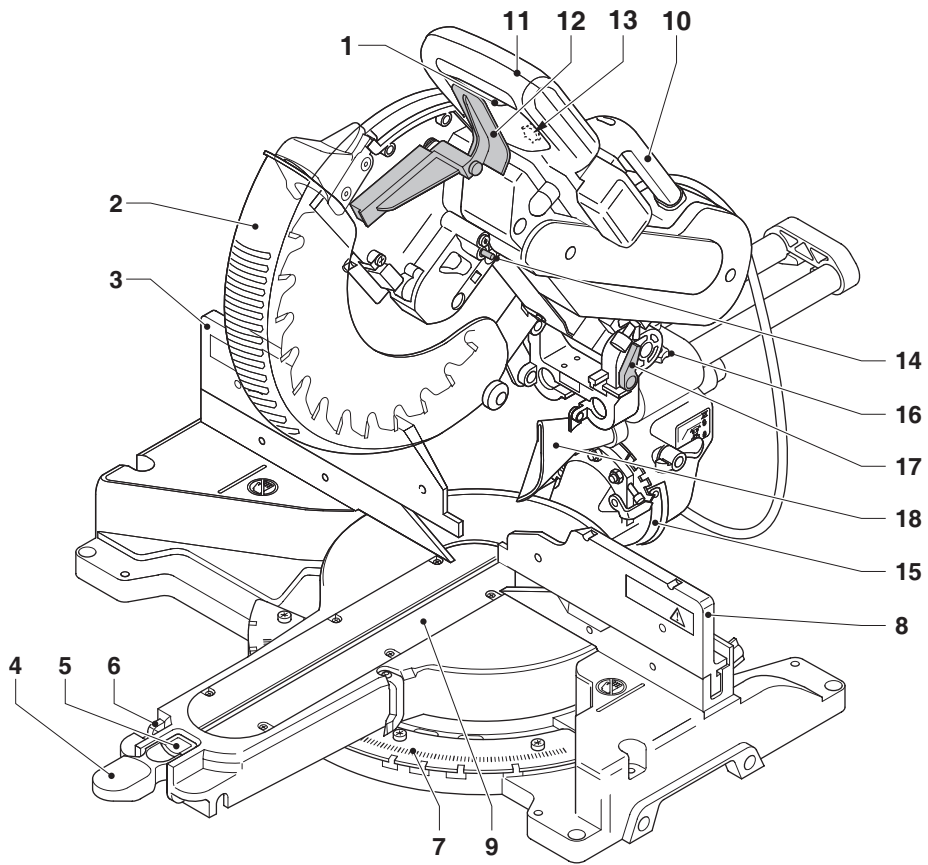

A1

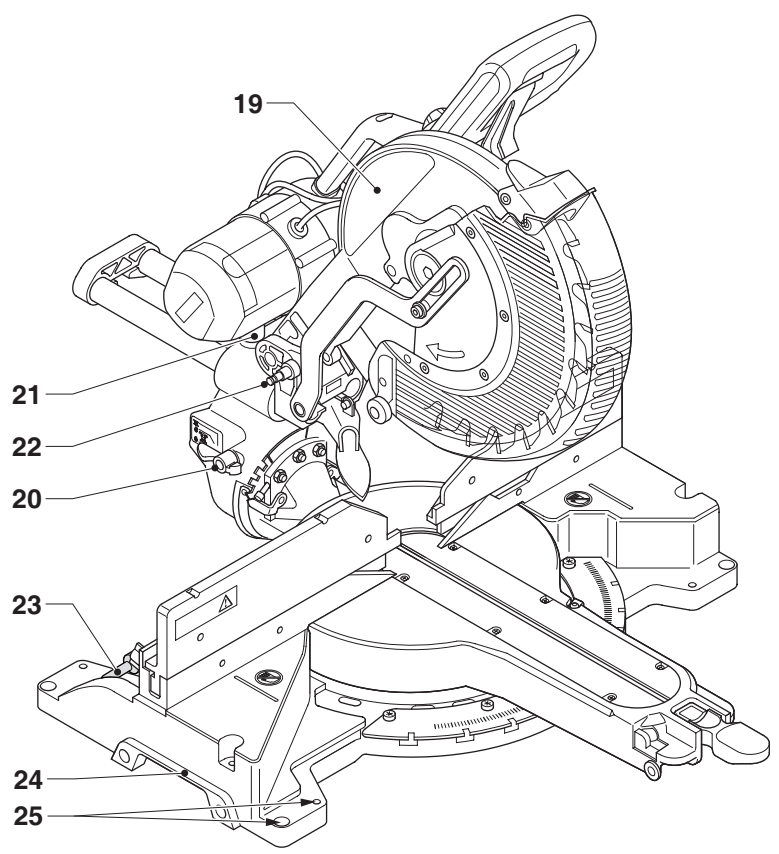

A2

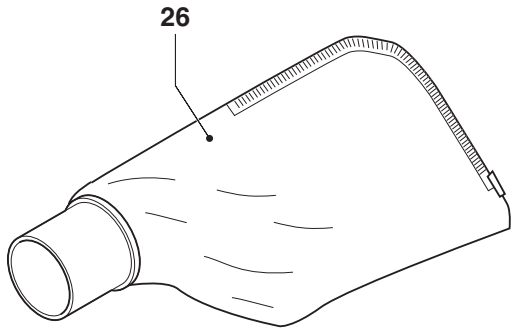

A3

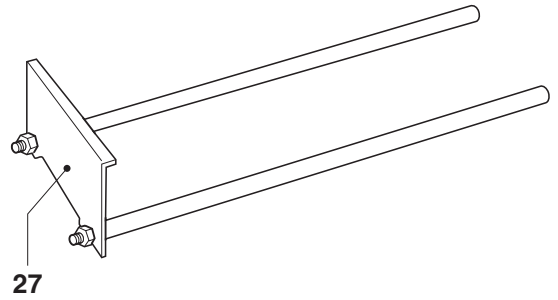

A4

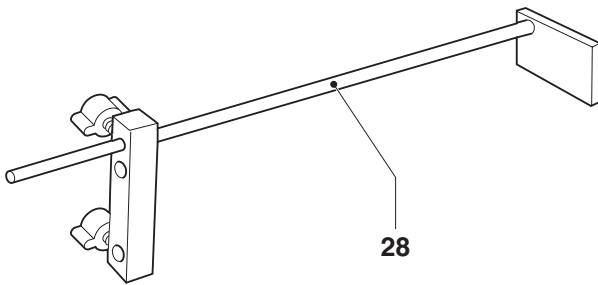

A5

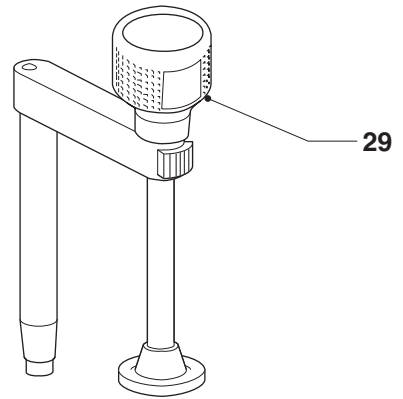

A6

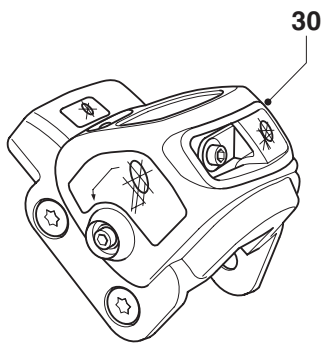

A7

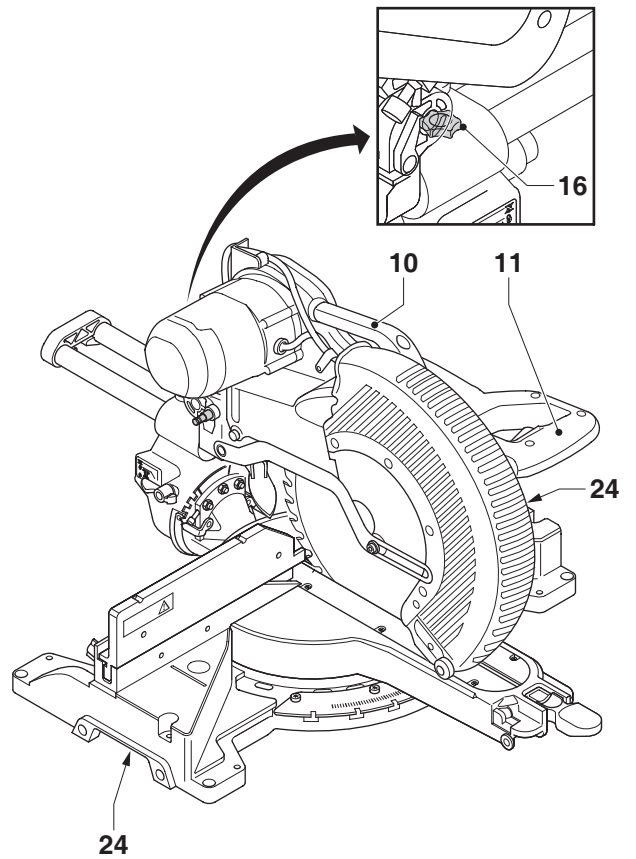

B

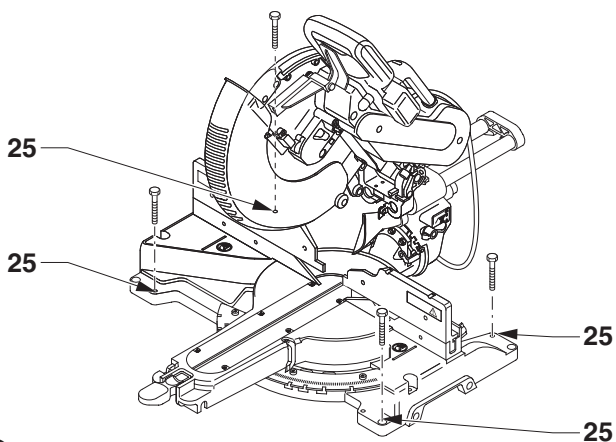

C

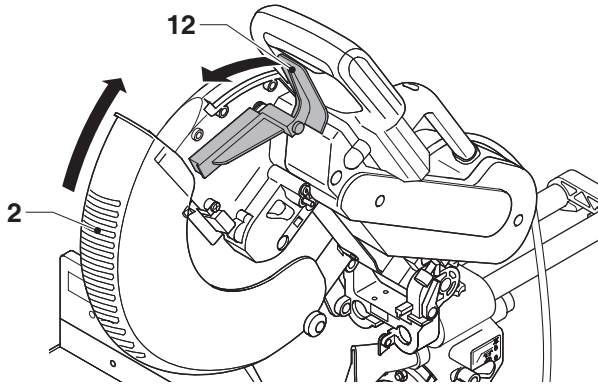

D1

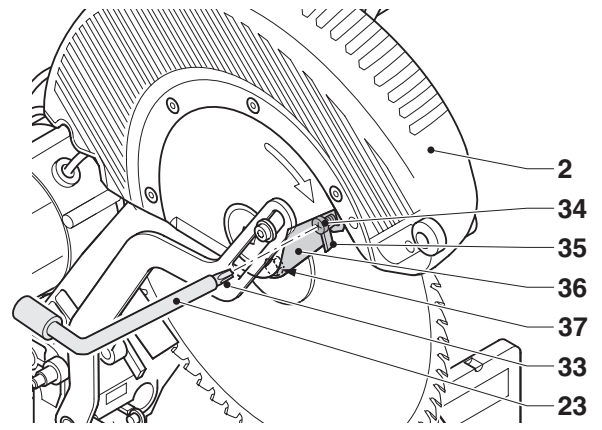

D2

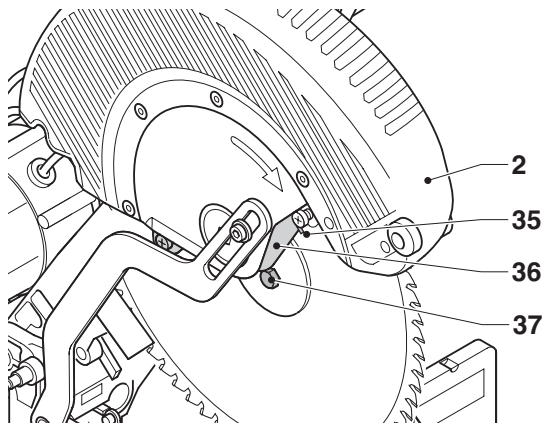

D3

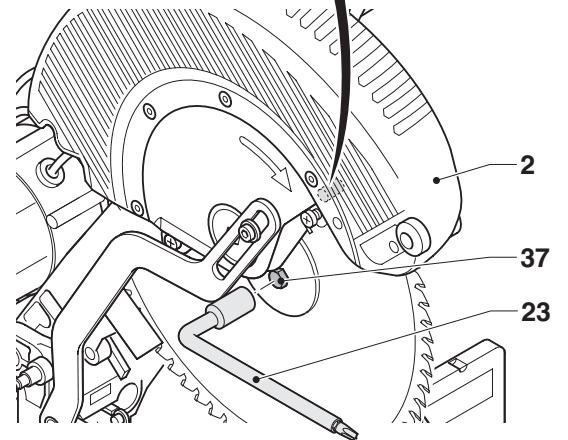
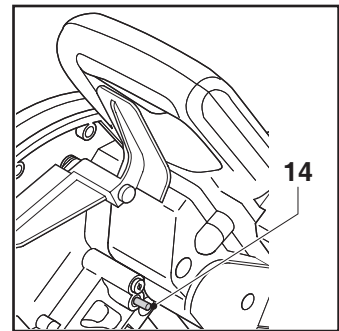

D4

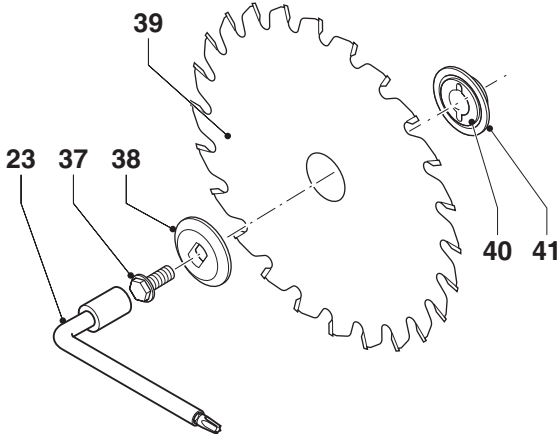

D5

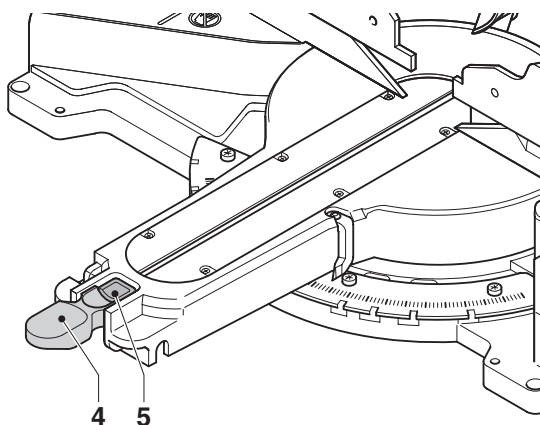

E1

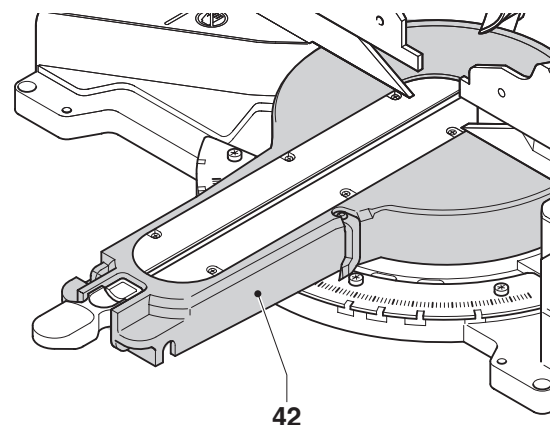

E2

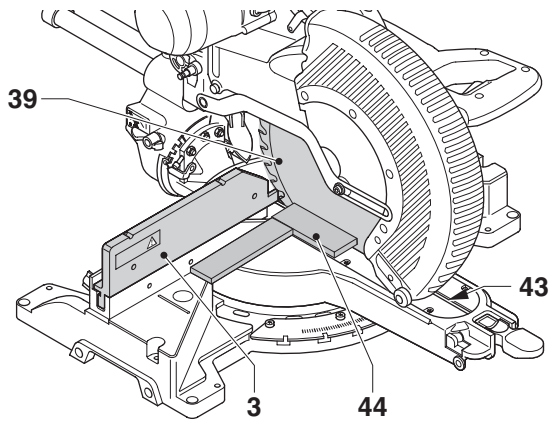

E3

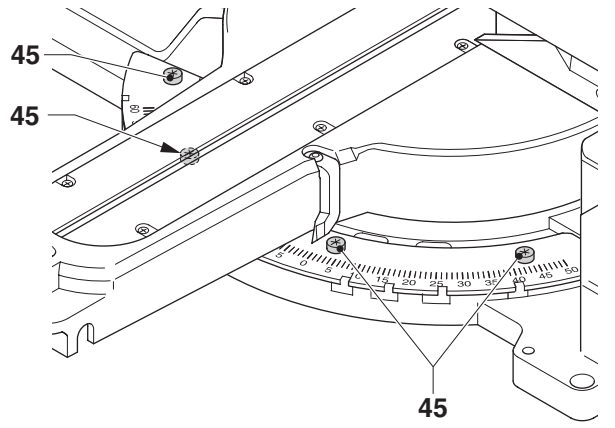

E4

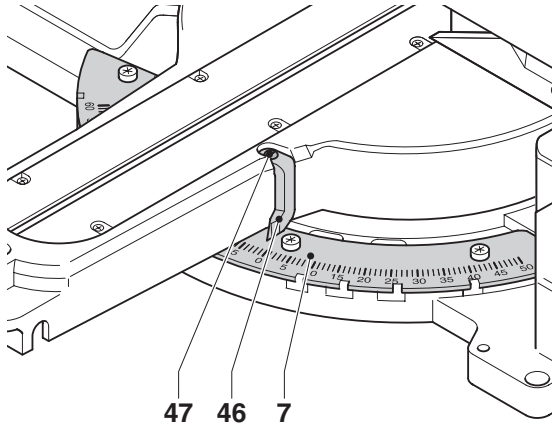

F

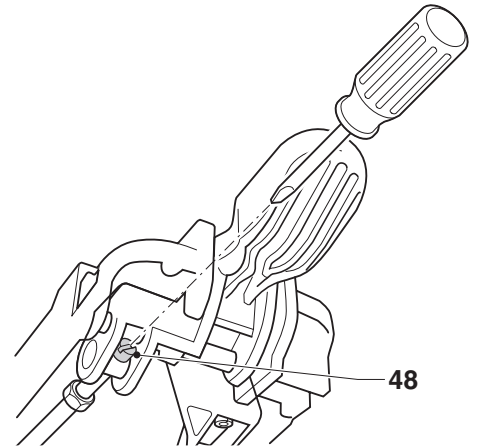

G

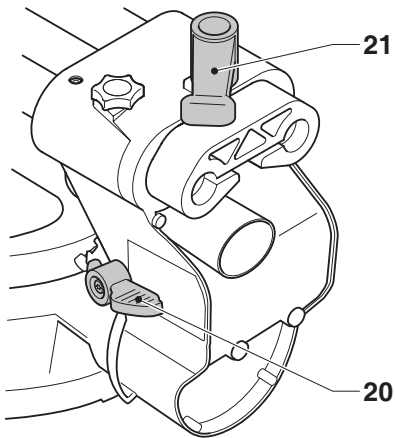

H1

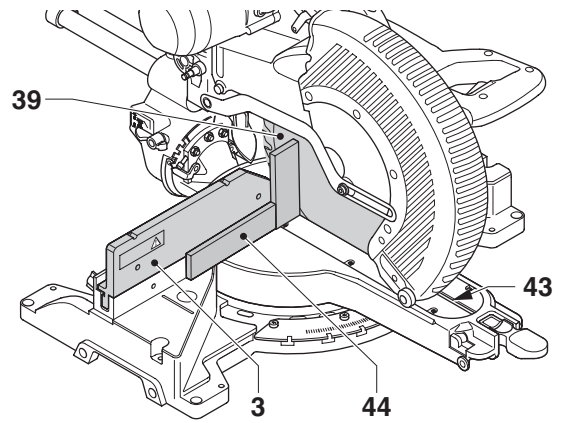

H2

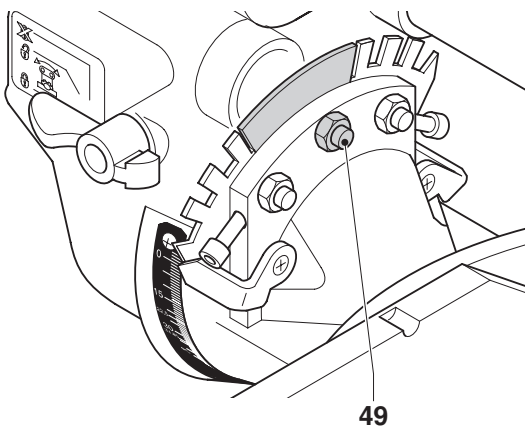

H3

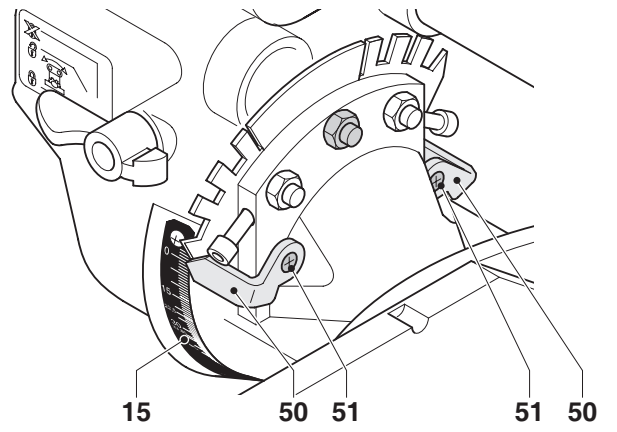

H4

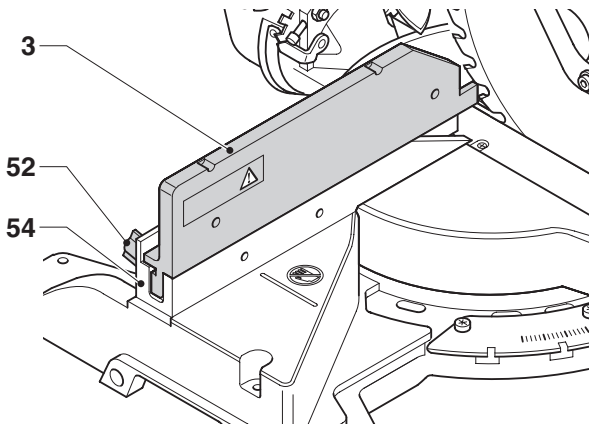

I1

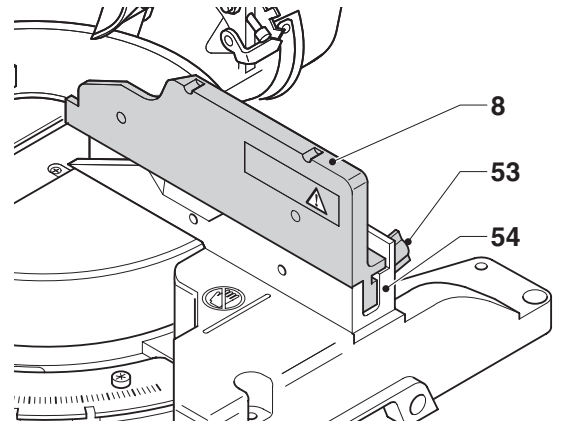

I2

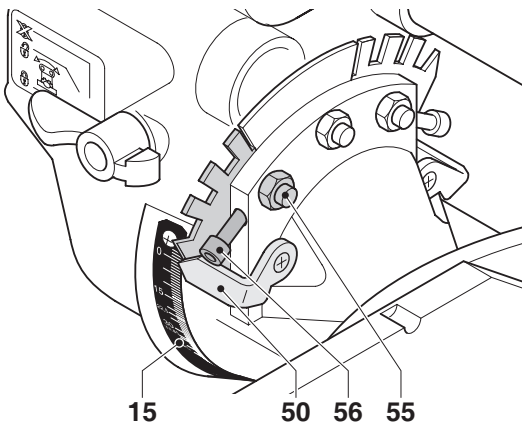

J1

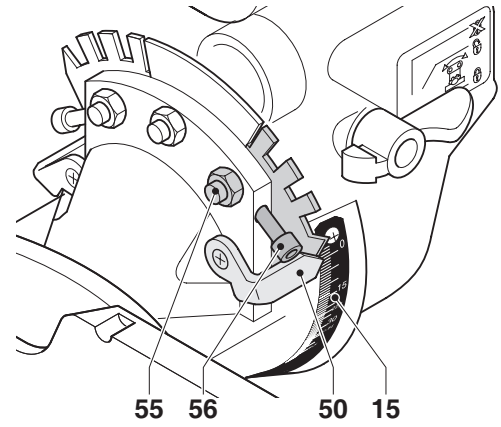

J2

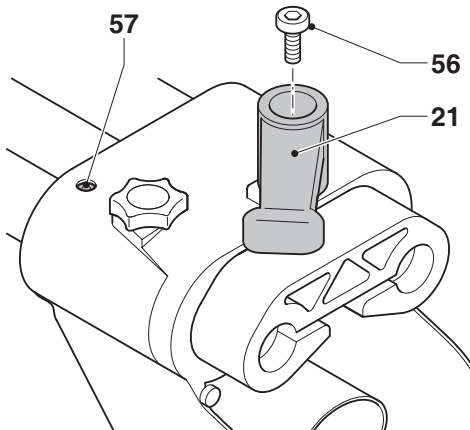

K

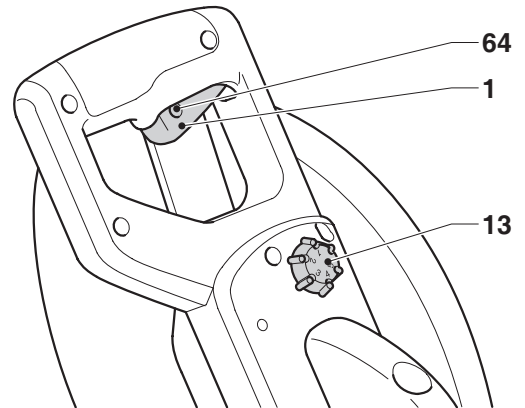

L

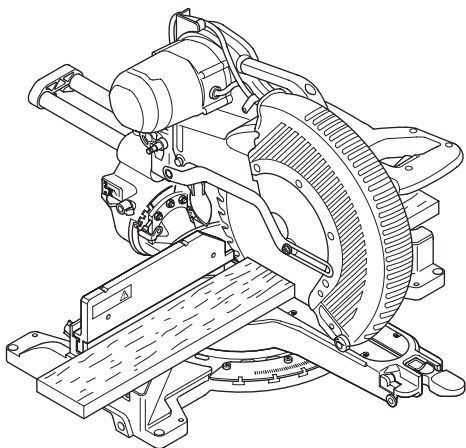

M

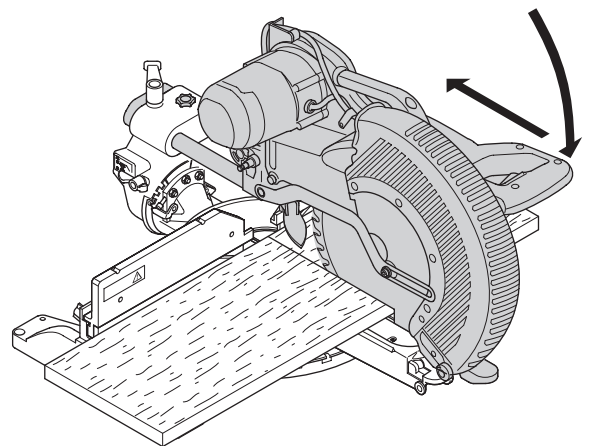

N

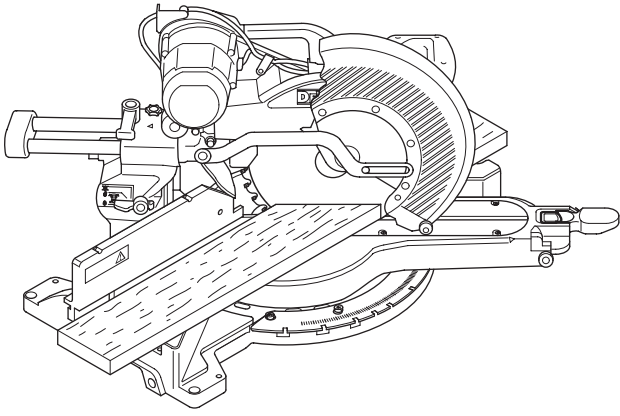

O

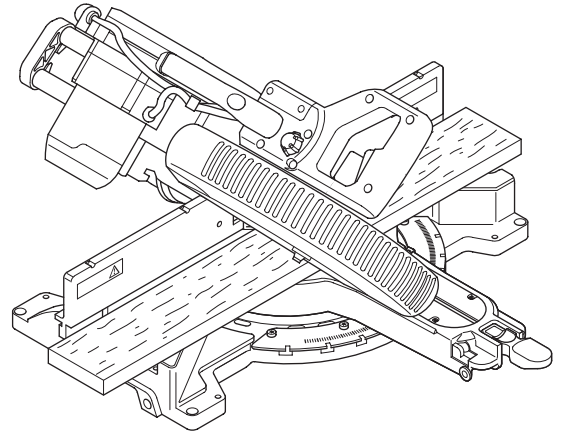

P

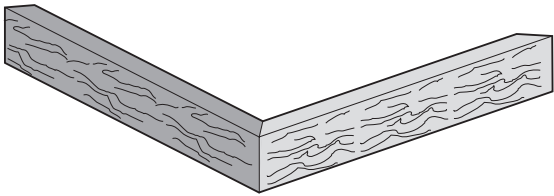

Q1

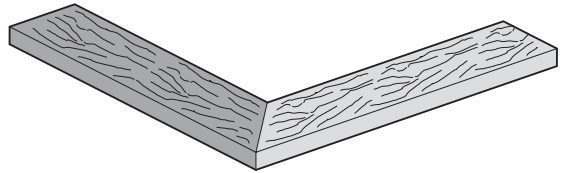

Q2

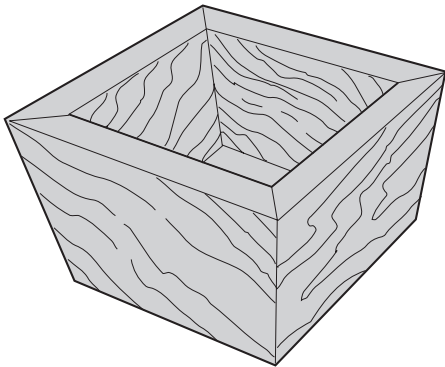

R1

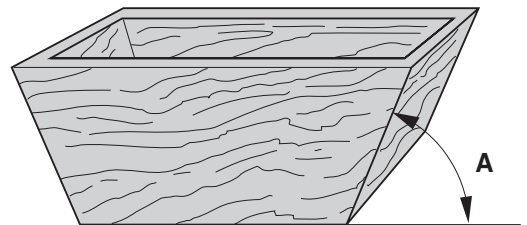

R2

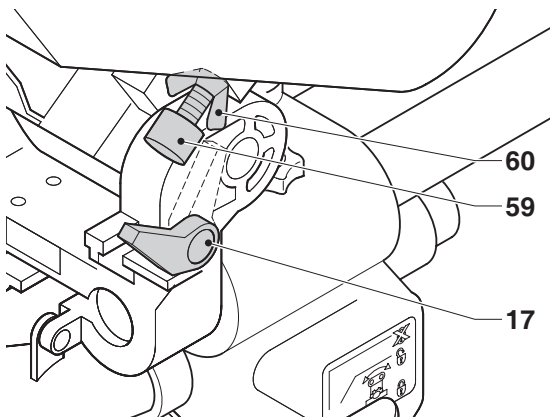

S

MITRE SAW DW718

Congratulations!

You have chosen a DeWALT tool. Years of experience, thorough product development and innovation make DeWALT one of the most reliable partners for professional power tool users.

Technical data

	DW718
Voltage	V 230
(U.K. & Ireland only)	V 230/115
Power input	W 1,600
Blade diameter	mm 305
Blade bore	mm 30
Blade body thickness	mm 1.8
Max. blade speed	min ⁻¹ 3,400
Max. cross-cut capacity 90°	mm 203
Max. mitre capacity 45°	mm 144
Max. depth of cut 90°	mm 85
Max. depth of bevel cross-cut 45°	mm 56
Mitre (max. positions)	left 60° right 50°
Bevel (max. positions)	left 48° right 48°
0° mitre	
Resulting width at max. height 94 mm	mm 328
Resulting height at max. width 345 mm	mm 74
45° mitre left	
Resulting width at max. height 94 mm	mm 231
Resulting height at max. width 241 mm	mm 74
45° mitre right	
Resulting width at max. height 94 mm	mm 231
Resulting height at max. width 241 mm	mm 74
45° bevel left	
Resulting width at max. height 61 mm	mm 328
Resulting height at max. width 345 mm	mm 48
45° bevel right	
Resulting width at max. height 43 mm	mm 328
Resulting height at max. width 345 mm	mm 28
31.62° mitre, 33.85° bevel	
Resulting height at max. width 168 mm	mm 23
Automatic blade brake time	s < 10.0
Weight	kg 20.5

Fuses:

Europe	230 V tools	10 Amperes, mains
U.K. & Ireland	230 V tools	13 Amperes, in plugs
U.K. & Ireland	115 V tools	16 Amperes, mains

The following symbols are used throughout this manual:



Denotes risk of personal injury, loss of life or damage to the tool in case of non-observance of the instructions in this manual.



Denotes risk of electric shock.

EC-Declaration of conformity



DW718

DeWALT declares that these power tools have been designed in compliance with: 98/37/EEC, 89/336/EEC, 73/23/EEC, 86/188/EEC, EN 55014-2, EN 55014, EN 61000-3-2, EN 61000-3-3 & EN 61029.

For more information, please contact DeWALT at the address below, or refer to the back of the manual.

	DW718
L _{pA} (sound pressure)	dB(A) 88
L _{WA} (acoustic power)	dB(A) 101
Weighted RMS acceleration value	m/s ² < 2.5*
K _{pA} (sound pressure uncertainty)	dB(A) 2.8
K _{WA} (acoustic power uncertainty)	dB(A) 2.8

* measurement uncertainty according to EN 12096: 0.4 m/s²

Director Engineering and Product Development
Horst Großmann

DeWALT, Richard-Klinger-Straße 40,
D-65510, Idstein, Germany

Safety instructions

When using stationary power tools, always observe the safety regulations applicable in your country to reduce the risk of fire, electric shock and personal injury.

Read all of this manual carefully before operating the tool.

Save this manual for future reference.

General

1 Keep work area clean

Cluttered areas and benches can cause accidents.

2 Consider work area environment

Do not expose the tool to rain. Do not use the tool in damp or wet conditions. Keep the work area well lit (250 - 300 Lux). Do not use the tool where there is a risk of causing fire or explosion, e.g. in the presence of flammable liquids and gases.

3 Keep children away

Do not allow children, visitors or animals to come near the work area or to touch the tool or the mains cable.

4 Dress properly

Do not wear loose clothing or jewellery, as these can be caught in moving parts. Wear protective hair covering to keep long hair out of the way. When working outdoors, preferably wear suitable gloves and non-slip footwear.

5 Personal protection

Always use safety glasses. Use a face or dust mask whenever the operations may produce dust or flying particles. If these particles might be considerably hot, also wear a heat-resistant apron. Wear ear protection at all times. Wear a safety helmet at all times.

6 Guard against electric shock

Prevent body contact with earthed or grounded surfaces (e.g. pipes, radiators, cookers and refrigerators). When using the tool under extreme conditions (e.g. high humidity, when metal swarf is being produced, etc.), electric safety can be improved by inserting an isolating transformer or a (FI) earth-leakage circuit-breaker.

7 Do not overreach

Keep proper footing and balance at all times.

8 Stay alert

Watch what you are doing. Use common sense. Do not operate the tool when you are tired.

9 Secure workpiece

Use clamps or a vice to hold the workpiece. It is safer and it frees both hands to operate the tool.

10 Connect dust extraction equipment

If devices are provided for the connection of dust extraction and collection facilities, ensure that these are connected and properly used.

11 Remove adjusting keys and wrenches

Always check that adjusting keys and wrenches are removed from the tool before operating the tool.

12 Extension cables

Before use, inspect the extension cable and replace if damaged. When using the tool outdoors, only use extension cables intended for outdoor use and marked accordingly.

13 Use appropriate tool

The intended use is described in this instruction manual. Do not force small tools or attachments to do the job of a heavy-duty tool. The tool will do the job better and safer at the rate for which it was intended. Do not force the tool.

Warning! The use of any accessory or attachment or performance of any operation with this tool other than those recommended in this instruction manual may present a risk of personal injury.

14 Check for damaged parts

Before use, carefully check the tool and mains cable for damage. Check for misalignment and seizure of moving parts, breakage of parts, damage to guards and switches and any other conditions that may affect its operation.

Ensure that the tool will operate properly and perform its intended function. Do not use the tool if any part is damaged or defective.

Do not use the tool if the switch does not turn it on and off. Have any damaged or defective parts replaced by an authorised DeWALT repair agent. Never attempt any repairs yourself.

15 Unplug tool

Switch off and wait for the tool to come to a complete standstill before leaving it unattended. Unplug the tool when not in use, before changing any parts of the tools, accessories or attachments and before servicing.

16 Avoid unintentional starting

Be sure that the tool is switched off before plugging in.

17 Do not abuse cord

Never pull the cord to disconnect from the socket. Keep the cord away from heat, oil and sharp edges.

18 Store idle tools

When not in use, tools must be stored in a dry place and locked up securely, out of reach of children.

19 Maintain tools with care

Keep the tools in good condition and clean for better and safer performance. Follow the instructions for maintenance and changing accessories. Keep all handles and switches dry, clean and free from oil and grease.

20 Repairs

This tool is in accordance with the relevant safety regulations. Have your tool repaired by an authorised DeWALT repair agent. Repairs should only be carried out by qualified persons using original spare parts; otherwise this may result in considerable danger to the user.

Additional safety rules for mitre saws

- Make sure all locking knobs and clamp handles are tight before starting any operation.
- Do not operate the machine without the guard in position, or if the guard does not function or is not maintained properly.
- Never use your saw without the kerf plate.
- Never place either hand in the blade area when the saw is connected to the electrical power source.
- Never attempt to stop a machine in motion rapidly by jamming a tool or other means against the blade; serious accidents can be caused unintentionally in this way.
- Before using any accessory consult the instruction manual. The improper use of an accessory can cause damage.
- Select the correct blade for the material to be cut.
- Observe the maximum speed marked on the saw blade.
- Use a holder or wear gloves when handling a saw blade.
- Ensure that the saw blade is mounted correctly before use.
- Make sure that the blade rotates in the correct direction. Keep the blade sharp.
- Do not use blades of larger or smaller diameter than recommended. For the proper blade rating refer to the technical data. Use only the blades specified in this manual, complying with EN 847-1.
- Consider applying specially designed noise-reduction blades.
- Do not use HSS blades.
- Do not use cracked or damaged saw blades.
- Do not use any abrasive discs.
- Raise the blade from the kerf in the workpiece prior to releasing the switch.
- Ensure that the arm is securely fixed when performing bevel cuts.
- Do not wedge anything against the fan to hold the motor shaft.
- The blade guard on your saw will automatically raise when the arm is brought down; it will lower over the blade when the arm is raised. The guard can be raised by hand when installing or removing saw blades or for inspection of the saw. Never raise the blade guard manually unless the saw is switched off.
- Keep the surrounding area of the machine well maintained and free of loose materials, e.g. chips and cut-offs.
- Check periodically that the motor air slots are clean and free of chips.

- Replace the kerf plate when worn.
- Disconnect the machine from the mains before carrying out any maintenance work or when changing the blade.
- Never perform any cleaning or maintenance work when the machine is still running and the head is not in the rest position.
- When possible, always mount the machine to a bench.
- If you use a laser to indicate the cutting line, make sure that the laser is of class 2 according to EN 60825-1:2001. Do not replace a laser diode with a different type. If damaged, have the laser repaired by an authorised repair agent.
- The front section of the guard is louvred for visibility while cutting. Although the louvres dramatically reduce flying debris, there are openings in the guard and safety glasses should be worn at all times when viewing through the louvres.

Residual risks

The following risks are inherent to the use of saws:

- injuries caused by touching the rotating parts

In spite of the application of the relevant safety regulations and the implementation of safety devices, certain residual risks cannot be avoided.

These are:

- Impairment of hearing.
- Risk of accidents caused by the uncovered parts of the rotating saw blade.
- Risk of injury when changing the blade.
- Risk of squeezing fingers when opening the guards.
- Health hazards caused by breathing dust developed when sawing wood, especially oak, beech and MDF.

Package contents

The package contains:

- 1 Assembled mitre saw
- 1 Blade spanner
- 1 Saw blade
- 1 Dustbag
- 1 Instruction manual
- 1 Exploded drawing

- Check for damage to the tool, parts or accessories which may have occurred during transport.
- Take the time to thoroughly read and understand this manual prior to operation.

Description (fig A1 - A7)

Your DW718 mitre saw has been designed for professional cutting of wood, wood products, aluminium and plastics. It will perform the sawing operations of cross-cutting, bevelling and mitring easily, accurately and safely.

A1

- 1 On/off switch
- 2 Moveable lower blade guard
- 3 Fence left-hand side
- 4 Mitre lever
- 5 Mitre latch
- 6 Mitre latch override lever
- 7 Mitre scale
- 8 Fence right-hand side
- 9 Kerf plate
- 10 Carrying handle
- 11 Operating handle
- 12 Head lock up release lever
- 13 Electronic speed control dial
- 14 Spindle lock
- 15 Bevel scale
- 16 Rail lock knob
- 17 Grooving stop
- 18 Dust spout

A2

- 19 Fixed upper blade guard
- 20 Bevel latch/lever
- 21 Bevel clamp handle
- 22 Head lock down pin
- 23 Blade spanner
- 24 Hand indentation
- 25 Bench mounting holes

A3

- 26 Dustbag

Optional accessories

A4

- 27 Work support extension

A5

- 28 Adjustable length stop

A6

- 29 Work piece clamp

A7

- 30 Laser

Electrical safety

The electric motor has been designed for one voltage only. Always check that the power supply corresponds to the voltage on the rating plate.



Your tool is double insulated in accordance with EN 61029; therefore no earth wire is required.

Mains plug replacement (U.K. & Ireland only)

- Should your mains plug need replacing and you are competent to do this, proceed as instructed below. If you are in doubt, contact an authorized DeWALT repair agent or a qualified electrician.
- Disconnect the plug from the supply.
- Cut off the plug and dispose of it safely; a plug with bared copper conductors is dangerous if engaged in a live socket outlet.
- Only fit 13 Amperes BS1363A approved plugs fitted with the correctly rated fuse (1).
- The cable wire colours, or a letter, will be marked at the connection points of most good quality plugs. Attach the wires to their respective points in the plug (see below). Brown is for Live (L) (2) and Blue is for Neutral (N) (4).
- Before replacing the top cover of the mains plug ensure that the cable restraint (3) is holding the outer sheath of the cable firmly and that the two leads are correctly fixed at the terminal screws.

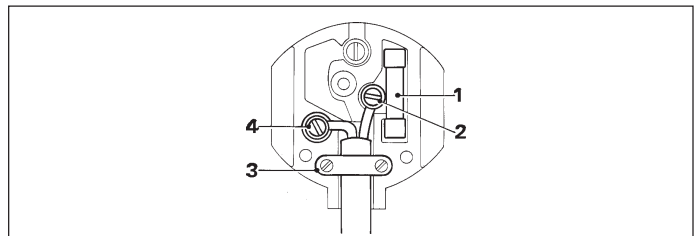

Never use a light socket.
Never connect the live (L) or neutral (N) wires to the earth pin marked E or ⊥.

Fitting a mains plug to 115 V units (U.K. & Ireland only)

- The plug should be fitted by a competent person. If you are in doubt, contact an authorized DeWALT repair agent or a qualified electrician.

The wires are coloured according to the following code:

live = brown
neutral = blue

- Do not connect the blue or brown wire to the earth terminal in the plug. Connect as follows:
brown to terminal marked 'L'
blue to terminal marked 'N'

The plug fitted should comply with BS EN 60309 (BS4343), 32 Amps.



Always ensure that the cable clamp is correctly and securely fitted to the sheath of the cable.

Using an extension cable

If an extension cable is required, use an approved extension cable suitable for the power input of this tool (see technical data).

The minimum conductor size is 1.5 mm².

When using a cable reel, always unwind the cable completely.

Also refer to the table below.

Conductor size (mm ²)	Cable rating (Amperes)	Cable length (m)					
		7.5	15	25	30	45	60
0.75	6						
1.00	10						
1.50	15						
2.50	20						
4.00	25						
Voltage	Amperes	Cable rating (Amperes)					
		7.5	15	25	30	45	60
115	0 - 2.0	6	6	6	6	6	10
	2.1 - 3.4	6	6	6	6	15	15
	3.5 - 5.0	6	6	10	15	20	20
	5.1 - 7.0	10	10	15	20	20	25
	7.1 - 12.0	15	15	20	25	25	-
230	0 - 2.0	6	6	6	6	6	6
	2.1 - 3.4	6	6	6	6	6	6
	3.5 - 5.0	6	6	6	6	10	15
	5.1 - 7.0	10	10	10	10	15	15
	7.1 - 12.0	15	15	15	15	20	20
	12.1 - 20.0	20	20	20	20	25	-

Voltage drops

Inrush currents cause short-time voltage drops. Under unfavourable power supply conditions, other equipment may be affected.

If the system impedance of the power supply is lower than 0.25 Ω, disturbances are unlikely to occur.

Assembly



Prior to assembly always unplug the tool.

Unpacking (fig. B)

- Remove the saw from the packing material carefully using the carrying handle (10).
- Release the rail lock knob (16), and push the saw head back to lock it in the rear position.
- Press down the operating handle (11) and pull out the lock down pin (22), as shown.
- Gently release the downward pressure and allow the arm to rise to its full height.

Bench mounting (fig. C)

- Holes (25) are provided in all four feet to facilitate bench mounting. Two different sized holes are provided to accommodate different sizes of bolts. Use either hole; it is not necessary to use both. Always mount your saw firmly to prevent movement. To enhance the portability, the tool can be mounted to a piece of 12.5 mm or thicker plywood which can then be clamped to your work support or moved to other job sites and reclamped.
- When mounting your saw to a piece of plywood, make sure that the mounting screws do not protrude from the bottom of the wood. The plywood must sit flush on the work support. When clamping the saw to any work surface, clamp only on the clamping bosses where the mounting screw holes are located. Clamping at any other point will interfere with the proper operation of the saw.
- To prevent binding and inaccuracy, be sure the mounting surface is not warped or otherwise uneven. If the saw rocks on the surface, place a thin piece of material under one saw foot until the saw is firm on the mounting surface.

Mounting the saw blade (fig. D1 - D5)

- Depress the head lock up release lever (12) to release the lower guard (2), then raise the lower guard as far as possible.
- Using the Torx bit (33) in the handgrip end of the supplied blade spanner (23), loosen the guard bracket screw (34) sufficiently to allow the angled corner piece (35) to pass between the head of the screw and the guard. This will allow the guard bracket (36) to be raised enough to permit access to the blade locking screw (37).
- With the lower guard held in the raised position by the guard bracket screw (34) depress the spindle lock button (14) with one hand, then use the supplied blade spanner (23) in the other hand to loosen the left-hand threaded blade locking screw (37) by turning clockwise.



To use the spindle lock, press the button as shown and rotate the spindle by hand until you feel the lock engage. Continue to hold the lock button in to keep the spindle from turning (fig. D4).

- Remove the blade locking screw (37) and the outside arbor collar (38).
- Install the saw blade (39) onto the shoulder (40) provided on the inside arbor collar (41), making sure that the teeth at the bottom edge of the blade are pointing toward the back of the saw (away from the operator).
- Replace the outer arbor collar (38).
- Tighten the blade locking screw (37) by turning counter-clockwise while holding the spindle lock engaged with your other hand.
- Move the guard bracket (36) down until the angled corner piece (35) is below the head of the guard bracket screw (34).
- Tighten the guard bracket screw.



Never press the spindle lock while the blade is rotating. Be sure to hold the guard bracket down and firmly tighten the guard bracket screw after installing the blade.

Adjustment



Prior to adjustment always unplug the tool.

Your mitre saw was accurately adjusted at the factory. If readjustment due to shipping and handling or any other reason is required, follow the steps below to adjust your saw. Once made, these adjustments should remain accurate.

Checking and adjusting the blade to the fence (fig. E1 - E4)

- Release the mitre lever (4) and depress the mitre latch (5) to release the mitre arm (42).
- Swing the mitre arm until the latch locates it at the 0° mitre position. Do not tighten the lever.

- Pull down the head until the blade just enters the saw kerf (43).
- Place a square (44) against the left side of the fence (3) and blade (39) (fig. E3).



Do not touch the tips of the blade teeth with the square.

- If adjustment is required, proceed as follows:
- Loosen the screws (45) and move the scale/mitre arm assembly left or right until the blade is at 90° to the fence as measured with the square.
- Retighten the screws (45). Pay no attention to the reading of the mitre pointer at this point.

Adjusting the mitre pointer (fig. E1, E2 & F)

- Release the mitre lever (4) and depress the mitre latch (5) to release the mitre arm (42).
- Move the mitre arm to set the mitre pointer (46) to the zero position, as shown in fig. F.
- With the mitre lever loose, allow the mitre latch to snap into place as you rotate the mitre arm past zero.
- Observe the pointer (46) and mitre scale (7). If the pointer does not indicate exactly zero, loosen the screw (47), move the pointer to read 0° and tighten the screw.

Mitre lock/detent rod adjustment (fig. G)

If the base of the saw can be moved while the mitre lever (4) is locked, the mitre lock/detent rod (48) must be adjusted.

- Unlock the mitre lever (4).
- Fully tighten the mitre lock/detent rod (48) using a screwdriver. Then loosen the rod a quarter of a turn.
- Check that the table does not move when the lever (4) is locked at a random (not preset) angle.

Checking and adjusting the blade to the table (fig. H1 - H4)

- Loosen the bevel clamp handle (21) and lift the bevel latch (20) to release the saw arm.
- Move the saw arm until the latch locates it at the 0° bevel position. Do not tighten the handle.
- Pull down the head until the blade just enters the saw kerf (43).
- Place a set square (44) on the table and up against the blade (39) (fig. H2).



Do not touch the tips of the blade teeth with the square.

- If adjustment is required, proceed as follows:
- Loosen the nut (49) and move the saw arm assembly left or right until the blade is at 90° to the table as measured with the square. Retighten the nut (49).
- If the bevel pointer (50) does not indicate zero on the bevel scale (15), loosen the screw (51) that secures the pointer and move the pointer as necessary. Repeat as for the bevel pointer located on the opposite side.

Adjusting the fence (fig. I1 & I2)

The upper part of the fence can be adjusted to provide clearance, allowing the saw to bevel to a full 48° both left and right. To adjust the left fence (3):

- Loosen the plastic knob (52) and slide the fence to the left.
- Make a dry run with the saw switched off and check for clearance. Adjust the fence to be as close to the blade as practical to provide maximum workpiece support, without interfering with the up and down movement of the arm.
- Tighten the knob securely.

To adjust the right fence (8):

- Loosen the plastic knob (53) and slide the fence to the right.
- Proceed as for adjusting the left fence.



The guide grooves (54) can become clogged with sawdust. Use a stick or some low pressure air to clear the guide grooves.

Checking and adjusting the bevel angle (fig. J1, J2, J1 & J2)

Checking and adjusting the left bevel angle

- Loosen the left side fence clamping knob (52) and slide the upper part of the left side fence to the left as far as it will go.
- Loosen the bevel clamp handle (21) and lift the bevel latch (20) to release the saw arm.
- Move the saw arm to the left until the latch locates it at the 45° bevel position. Do not tighten the handle.
- Check that the bevel indicator (50) indicates 45° on the bevel scale (15) (fig. J1).
- If adjustment is required, proceed as follows:
- Loosen the nut (55) and turn the stopscrew (56) in or out as necessary until the pointer (50) indicates 45°. Retighten the nut (55).
- To achieve a 50° bevel, turn the screw on the angle position stop out to allow the saw arm to move as necessary.

Checking and adjusting the right bevel angle

- Loosen the right side fence clamping knob (53) and slide the upper part of the right side fence to the left as far as it will go.
- Loosen the bevel clamp handle (21) and lift the bevel latch (20) to release the saw arm.
- Move the saw arm to the right until the latch locates it at the 45° bevel position. Do not tighten the handle.
- Check that the bevel indicator (50) indicates 45° on the bevel scale (15) (fig. J2).
- If adjustment is required, proceed as for adjusting the left bevel angle.

Adjusting the bevel clamping system (fig. K)

If the saw arm can be moved when the bevel clamp handle (21) is locked, the clamping system must be adjusted.

- Remove the screw (56) holding the handle.
- Lift off the handle and turn it 1/8 turn clockwise. Refit the screw.
- Check that the saw arm does not move when the bevel clamp handle (21) is locked at a random (not preset) angle.

Rail guide adjustment (fig. K)

- Regularly check the rails for clearance.
- To reduce clearance, gradually rotate the set screw (57) clockwise while sliding the saw head back and forth.

Instructions for use



Always observe the safety instructions and applicable regulations.

The attention of UK users is drawn to the “woodworking machines regulations 1974” and any subsequent amendments.

Prior to operation:

- Install the appropriate saw blade. Do not use excessively worn blades. The maximum rotation speed of the tool must not exceed that of the saw blade.
- Do not attempt to cut excessively small pieces.
- Allow the blade to cut freely. Do not force.
- Allow the motor to reach full speed before cutting.
- Make sure all locking knobs and clamp handles are tight.
- Secure the workpiece.
- Although this saw will cut wood and many nonferrous materials, these operating instructions refer to the cutting of wood only. The same guide-lines apply to the other materials.

Do not cut ferrous (iron and steel) materials, fibre cement or masonry with this saw!

- Make sure to use the kerf plate. Do not operate the machine if the kerf slot is wider than 10 mm.

Switching on and off (fig. L)

A hole (58) is provided in the on/ off switch (1) for insertion of a padlock to lock the tool.

- To run the tool, press the on/off switch (1).
- To stop the tool, release the switch.

Setting the variable speed (fig. L)

The speed control dial (13) can be used for advance setting of the required range of speed.

- Turn the speed control dial (13) to the desired range, which is indicated by a number.
- Use high speeds for sawing soft materials such as wood.
Use low speeds for sawing metal.

Basic saw cuts

Vertical straight cross cut (fig. A1, A2 & M)

- Release the mitre lever (4) and depress the mitre latch (5) to release the mitre arm.
- Engage the mitre latch at the 0° position and tighten the mitre lever.
- Place the wood to be cut against the fence (3 & 8).
- Take hold of the operating handle (11) and depress the head lock up release lever (12) to release the head.
- Press the trigger switch (1) to start the motor.
- Depress the head to allow the blade to cut through the timber and enter the plastic kerf plate (9).
- After completing the cut, release the switch and wait for the saw blade to come to a complete standstill before returning the head to its upper rest position.

Performing a sliding cut (fig. N)

The guide rail allows cutting larger workpieces from 50 x 100 mm up to 500 x 1000 mm using an out-down-back sliding motion.

- Release the rail lock knob (16).
- Pull the saw head towards you and switch the tool on.
- Lower the saw blade into the workpiece and push the head back to complete the cut.
- Proceed as described above.



- Do not perform sliding cuts on workpieces smaller than 50 x 100 mm.
- Remember to lock the saw head in the rear position when the sliding cuts are finished.

Vertical mitre cross-cut (fig. A1, A2 & O)

- Release the mitre lever (4) and depress the mitre latch (5).
- Move the arm left or right to the required angle. The mitre latch will automatically locate at 10°, 15°, 22.5°, 31.62° and 45° both left and right, and at 60° left and 50° right. If any intermediate angle is required hold the head firmly and lock by tightening the mitre lever.
- Always ensure that the mitre lever is locked tightly before cutting.
- Proceed as for a vertical straight cross-cut.



When mitring the end of a piece of wood with a small off-cut, position the wood to ensure that the off-cut is to the side of the blade with the greater angle to the fence; i.e. left mitre, off-cut to the right - right mitre, off-cut to the left.

Bevel cuts (fig. A1, A2 & P)

Bevel angles can be set from 48° left to 48° right and can be cut with the mitre arm set between zero and a maximum of 45° mitre position right or left.

Left bevel

- Slide the upper part of the left side fence (3) to the left as far as it will go.
- Loosen the bevel clamp handle (21), lift the bevel latch (20) and set the bevel as desired.
- The bevel latch automatically locates at 22.5°, 33.85° and 45°. If any intermediate angle is required, hold the head firmly and lock by tightening the bevel clamp handle (21).
- Proceed as for a vertical straight cross-cut.

Right bevel

- Slide the upper part of the right side fence (8) to the right as far as it will go.
- Proceed as for a left bevel cut.

Quality of cut

The smoothness of any cut depends on a number of variables, e.g. the material being cut. When smoothest cuts are desired for moulding and other precision work, a sharp (60 tooth carbide) blade and a slower, even cutting rate will produce the desired results.



Ensure that the material does not creep while cutting; clamp it securely in place. Always let the blade come to a full stop before raising the arm. If small fibres of wood still split out at the rear of the workpiece, stick a piece of masking tape on the wood where the cut will be made. Saw through the tape and carefully remove tape when finished.

Body and hand position

Proper positioning of your body and hands when operating the mitre saw will make cutting easier, more accurate and safer.

- Never place your hands near the cutting area.
- Place your hands no closer than 150 mm from the blade.
- Hold the workpiece tightly to the table and the fence when cutting. Keep your hands in position until the switch has been released and the blade has completely stopped.
- Always make dry runs (without power) before finish cuts so that you can check the path of the blade.
- Do not cross your hands.
- Keep both feet firmly on the floor and maintain proper balance.
- As you move the saw arm left and right, follow it and stand slightly to the side of the saw blade.
- Sight through the guard louvres when following a pencil line.

Clamping the workpiece (fig. A6)

- Whenever possible, clamp the wood to the saw.
- For best results use the clamp (29) made for use with your saw. Clamp the workpiece to the fence whenever possible. You can clamp to either side of the saw blade; remember to position your clamp against a solid, flat surface of fence.



Always use a material clamp when cutting non-ferrous metals.

Support for long pieces (fig. A4)

- Always support long pieces.
- For best results, use the extension work support (27) to extend the table width of your saw (available from your dealer as an option). Support long workpieces using any convenient means such as saw-horses or similar devices to keep the ends from dropping.

Cutting picture frames, shadow boxes & other four sided projects (fig. Q1 & Q2)

Trim moulding and other frames

Try a few simple projects using scrap wood until you develop a “feel” for your saw. Your saw is the perfect tool for mitring corners like the one shown in fig. Q1. The joint shown has been made using either bevel adjustment.

- Using bevel adjustment

The bevel for the two boards is adjusted to 45° each, producing a 90° corner. The mitre arm is locked in the zero position. The wood is positioned with the broad flat side against the table and the narrow edge against the fence.

- Using mitre adjustment

The same cut can be made by mitring right and left with the broad surface against the fence.

The two sketches (fig. Q1 & Q2) are for four side objects only. As the number of sides changes, so do the mitre and bevel angles. The chart below gives the proper angles for a variety of shapes, assuming that all sides are of equal length. For a shape that is not shown in the chart, divide 180° by the number of sides to determine the mitre or bevel angle.

No. of sides	Angle mitre or bevel
4	45°
5	36°
6	30°
7	25.7°
8	22.5°
9	20°
10	18°

Compound mitre (fig. R1 & R2)

A compound mitre is a cut made using a mitre angle (fig. Q2) and a bevel angle (fig. Q1) at the same time. This is the type of cut used to make frames or boxes with slanting sides like the one shown in fig. R1.



If the cutting angle varies from cut to cut, check that the bevel clamp knob and the mitre lock knob are securely tightened. These knobs must be tightened after making any changes in bevel or mitre (fig. R1 & R2).

A compound mitre is a cut made using a mitre angle (fig. Q2) and a bevel angle (fig. Q1) at the same time. This is the type of cut used to make frames or boxes with slanting sides like the one shown in fig. R1.



If the cutting angle varies from cut to cut, check that the bevel clamp knob and the mitre lock knob are securely tightened. These knobs must be tightened after making any changes in bevel or mitre.

- The chart shown below will assist you in selecting the proper bevel and mitre settings for common compound mitre cuts. To use the chart, select the desired angle “A” (fig. R2) of your project and locate that angle on the appropriate arc in the chart. From that point follow the chart straight down to find the correct bevel angle and straight across to find the correct mitre angle.
- Set your saw to the prescribed angles and make a few trial cuts.
- Practice fitting the cut pieces together.
- Example: To make a 4 sided box with 25° exterior angles (angle “A”) (fig. R2), use the upper right arc. Find 25° on the arc scale. Follow the horizontal intersecting line to either side to get the mitre angle setting on the saw (23°). Likewise follow the vertical intersecting line to the top or bottom to get the bevel angle setting on the saw (40°). Always try cuts on a few scrap pieces of wood to verify the settings on the saw.

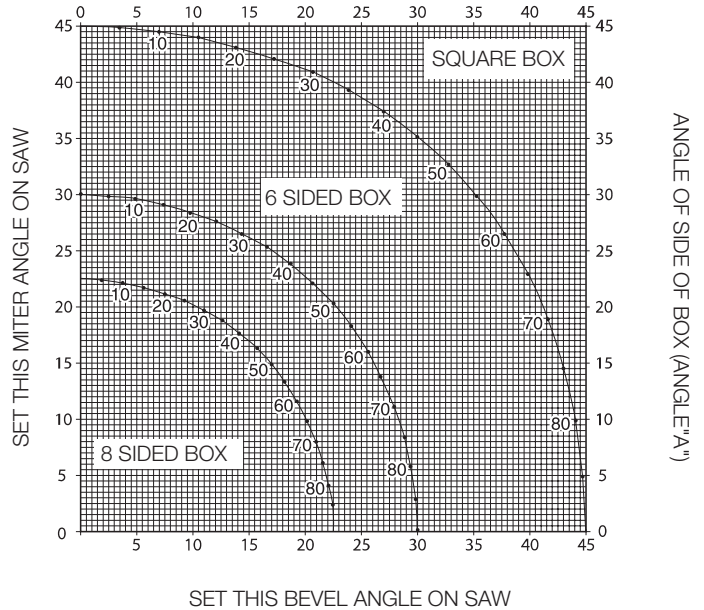

Cutting base mouldings

The cutting of base moulding is performed at a 45° bevel angle.

- Always make a dry run without power before making any cuts.
- All cuts are made with the back of the moulding laying flat on the saw.

Inside corner

- Left side
 - Position the moulding with top of the moulding against the fence.
 - Save the left side of the cut.
- Right side
 - Position the moulding with the bottom of the moulding against the fence.
 - Save the left side of the cut.

Outside corner

- Left side
 - Position the moulding with the bottom of the moulding against the fence.
 - Save the right side of the cut.
- Right side
 - Position the moulding with top of the moulding against the fence.
 - Save the right side of the cut.

Cutting crown mouldings

The cutting of crown moulding is performed in a compound mitre. In order to achieve extreme accuracy, your saw has pre-set angle positions at 31.62° mitre and 33.85° bevel. These settings are for standard crown mouldings with 52° angles at the top and 38° angles at the bottom.

- Make test cuts using scrap material before doing the final cuts.
- All cuts are made in a left bevel and with the back of the moulding against the base.

Inside corner

- Left side
 - Top of the moulding against the fence.
 - Mitre right.
 - Save the left side of the cut.

- Right side
 - Bottom of the moulding against the fence.
 - Mitre left.
 - Save the left side of the cut.

Outside corner

- Left side
 - Bottom of the moulding against the fence.
 - Mitre left.
 - Save the right side of the cut.
- Right side
 - Top of the moulding against the fence.
 - Mitre right.
 - Save the right side of the cut.

Grooving (fig. S)

Your saw is equipped with a grooving stop (17) and thumbscrew (59) to allow for groove cutting.

- Flip the grooving stop (17) towards the front of the saw.
- Adjust the thumbscrew (59) to set the depth of the groove cut. It might be necessary to release the lock nut (60) first.
- Place a piece of scrap material of approx. 5 cm between fence and workpiece in order to perform a straight groove cut.

Dust extraction (fig. A2 & A3)

- Fit the dustbag (26) onto the dust spout (18).
- Whenever possible, connect a dust extraction device designed in accordance with the relevant regulations regarding dust emission.

Saw blades

To obtain the stated cutting capacities, always use 305 mm saw blades with 30 mm arbor holes.

Cutting non-ferrous metals

When cutting non-ferrous metals, the machine is only to be used in the mitre saw mode. We recommend that bevel and compound mitre cuts should not be performed in non-ferrous metals. The machine is not to be used for cutting ferrous metals.

- Always use a material clamp when cutting non-ferrous metals. Make sure that the workpiece is clamped securely.
- Only apply saw blades that are qualified for cutting non-ferrous metals.
- When using lubricants, only apply wax or separation spray. Do not use emulsions or similar fluids.
- Connect an FI or DI switch between machine and mains to avoid residual risks caused by metal swarf.

The FI switch should comply with the following specifications:

rated voltage	230 V
rated current	16 A
reaction time	< 15 ms
fusing current	30 mA

The DI switch should comply with the following specifications:

DIN VDE 0661	
rated voltage	230 V
rated current	16 A
fusing current	30 mA
all-pole cutoff	L+N+PE
PE monitoring	
low-voltage release	

Optional accessories

Consult your dealer for further information on the appropriate accessories.

Transporting (fig. A1, A2 & B)

In order to conveniently carry the mitre saw, a carrying handle (10) has been included on the top of the saw arm.

- To transport the saw, lower the head and depress the lock down pin (22).
- Lock the rail lock knob with the saw head in the front position, lock the mitre arm in the utter right mitre angle, slide the fence (3 & 8) completely inward and lock the bevel lever (20) with the saw head in the vertical position to make the tool as compact as possible.
- Always use the carrying handle (10) or the hand indentations (24) shown in fig. B to transport the saw.

Maintenance

Your DeWALT power tool has been designed to operate over a long period of time with a minimum of maintenance. Continuous satisfactory operation depends upon proper tool care and regular cleaning.



Cleaning

Keep the ventilation slots clear and regularly clean the housing with a soft cloth.

- Regularly clean the table top.
- Regularly clean the dust collection system.



Avoid the use of cleaners or lubricants to maintain the tool. In particular spray and aerosol cleaners may chemically attack the plastic lower guard.



Lubrication

Your power tool requires no additional lubrication.

Protecting the environment



Separate collection. This product must not be disposed of with normal household waste.

Should you find one day that your DeWALT product needs replacement, or if it is of no further use to you, do not dispose of it with household waste. Make this product available for separate collection.



Separate collection of used products and packaging allows materials to be recycled and used again. Re-use of recycled materials helps prevent environmental pollution and reduces the demand for raw materials.

Local regulations may provide for separate collection of electrical products from the household, at municipal waste sites or by the retailer when you purchase a new product.

DeWALT provides a facility for the collection and recycling of DeWALT products once they have reached the end of their working life. To take advantage of this service please return your product to any authorised repair agent who will collect them on our behalf.

You can check the location of your nearest authorised repair agent by contacting your local DeWALT office at the address indicated in this manual. Alternatively, a list of authorised DeWALT repair agents and full details of our after-sales service and contacts are available on the Internet at: www.2helpU.com

GUARANTEE

• **30 DAY NO RISK SATISFACTION GUARANTEE** •

If you are not completely satisfied with the performance of your DeWALT machine, simply return it within 30 days, complete as purchased, to the point of purchase, for a full refund or exchange. Proof of purchase must be produced.

• **ONE YEAR FREE SERVICE CONTRACT** •

If you need maintenance or service for your DeWALT machine, in the 12 months following purchase, it will be undertaken free of charge at an authorized DeWALT repair agent. Proof of purchase must be produced. Includes labour and spare parts for Power Tools. Excludes accessories.

• **ONE YEAR WARRANTY** •

If your DeWALT product becomes defective due to faulty materials or workmanship within 12 months from the date of purchase, we guarantee to replace all defective parts free of charge or, at our discretion, replace the unit free of charge provided that:

- The product has not been misused.
- Repairs have not been attempted by unauthorized persons.
- Proof of purchase date is produced.

This guarantee is offered as an extra benefit and is additional to consumers statutory rights.

For the location of your nearest authorized DeWALT repair agent, please use the appropriate telephone number on the back of this manual. Alternatively, a list of authorized DeWALT repair agents and full details on our after-sales service are available on the Internet at www.2helpU.com